



The Lemcol range of materials handling equipment has been designed and manufactured to provide high quality, low maintenance products suitable for factory and general use. They reduce the physical effort involved in many manual handling operations and improve efficiency, as well as provide a safer working environment.

Lemcol Drum Rack

This sturdy built rack has been designed to facilitate convenient, safe and efficient stowage of drums and barrels for decanting.

Taking the backbreaking work out of drum handling, they are indispensable in garages, warehouses and factories.

A standard Lemcol 75mm nylon wheel is used for ease of replacement.

12 Month Warranty:

This range carries our standard 12 month warranty against faulty workmanship and materials, and is backed by a service and parts network Australia wide.

DRUM RACK				Bung Height (mm)	Wheel Model No.	Wheel Dia. (mm)	Model Number	Product Code
Length (mm)	Base Width (mm)	Top Width (mm)	Top Rail Height (mm)	560	L3400N	75	L30	04921402

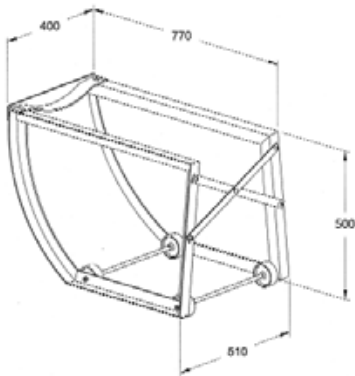

1. Simply wheel the cradle to the drum, up-end rack and slightly tilt drum to engage cradle lip with drum rim.

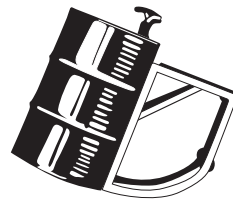

2. An easy push starts drum and cradle back to horizontal position.

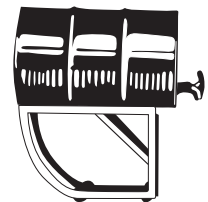

3. The drum can now be wheeled to the required position for decanting or storage.

The Lemcol range of materials handling equipment has been designed and manufactured to provide high quality, low maintenance products suitable for factory and general use. They reduce the physical effort involved in many manual handling operations and improve efficiency, as well as provide a safer working environment.

Lemcol Drum Truck

This product has been manufactured for ease of handling full 200 litre drums and hogsheads.

Due to the unique design, size and relative weight makes almost no difference to the balance and efficiency of the Drum Truck.

The L60 is of steel construction with strain points specially reinforced to withstand the toughest treatment.

The models are offered with two types of wheels. Cushion tyred wheels provide a greater capacity while having the added advantage of being puncture-proof. Pneumatic wheels are offered where greater shock absorbency is required or where operating conditions are a consideration.

When stored in an upright position, the compact L60 requires only 0.3m² of floor space.

12 Month Warranty

This range carries our standard 12 month warranty against faulty workmanship and materials, and is backed by a service and parts network Australia wide.



DRUM TRUCKS						
Width (mm)	Capacity (kg)	Wheel Model No.	Wheel Type	Wheel Dia. (mm)	Model Number	Product Code
600	320	L11250RLD-K	Cushion	280	L60S	04920704
600	280	L4210RLD-KB	Pneumatic	270	L60P	01057254

The drum truck can be loaded and unloaded in three easy stages

1. Bring the specially chiselled toe plate into contact with the drum.

2. Tilt handles forward until the spring loaded catch grip passes over the drum's edge and locks into position.

3. Apply weight to the footrest while tilting backwards so that the drum rests on the truck.

Unload by simply touching the catch grip and lift the handles simultaneously.



Models and specifications are subject to change without notice, all dimensions are nominal

Adelaide Tel: 08 8229 7800 Fax: 08 8445 1802
Brisbane Tel: 07 3217 0699 Fax: 07 3217 0822
Sydney Tel: 02 9648 3866 Fax: 02 9648 3599
Perth Tel: 08 9277 6999 Fax: 08 9331 1563
Melbourne Tel: 03 9548 9435 Fax: 03 9548 9460

